

# Apply Three IF Filters with the MAX2308 IF Receiver IC in Tri-band Wireless Handsets

*This application note describes how to apply three IF filters with the MAX2308 in a triple band wireless telephone system. Compares and contrasts approaches using an RF Switch at 183.6 MHz. A differential input and RF switch work together to improve insertion loss and minimize components. Sample schematics are given.*

Modern CDMA (code division multiple access) 3GPP cellular mobile radio standards require a GPS (global positioning system) receiver and must also support the legacy AMPS mode. Designers implement this by including three different IF (intermediate frequency) filters into the receiver. One IF filter serves the CDMA path, one serves AMPS, and one serves GPS. Unfortunately, even if the CDMA path is relatively wideband, it does not have enough bandwidth for a GPS receiver. This is why three IF filters are needed if both AMPS and GPS are used along with CDMA.

Maxim's MAX2308 IC is a highly integrated building block for low cost super heterodyne mobile telephone receivers. This IC includes a wide dynamic range dual-input IF variable gain amplifier (VGA), low phase noise IF VCO (voltage controlled oscillator) with PLL (phase locked loop) and an IQ demodulator. Efficiently applying the MAX2308 with three IF filters seems difficult to handset design engineers, since the MAX2308 inherently supports two IF filter paths. The MAX2308 was designed when two IF paths were thought to be sufficient for most wireless phone system standards.

## An RF Switch a 183.6 MHz

The common solution to supporting three IF filters with the MAX2308 is to include an RF SPDT (single pole, double throw) switch to multiplex two IF filters into one MAX2308 IF input. Normally this technique is used to switch between the AMPS and GPS IF filters.

The most commonly used IF frequency for all three filters is now 183.6 MHz. This frequency is too high for any common analog, low-frequency switch. High frequency switches have no problem operating at this frequency, at the cost of increased insertion loss (IL). Another issue the compounds the IL is that the RF switches are designed and specified for 50 $\Omega$  systems. Most IF SAW filters have output impedances of approximately 150 $\Omega$  and inputs of the IF VGA are on order of 1k ohm. Under these conditions a typical RF switch presents an insertion loss of roughly 5dB. The test schematic shown in Figure 1 is used to measure the insertion loss of any RF

switch with high impedance input and output loading. A typical IF SAW filter has 5 dB of insertion loss, which when added to the 5dB loss of the rf switch makes 10 dB of gain that the receiver must now supply. This may not be possible if the VGA has run out of dynamic range.

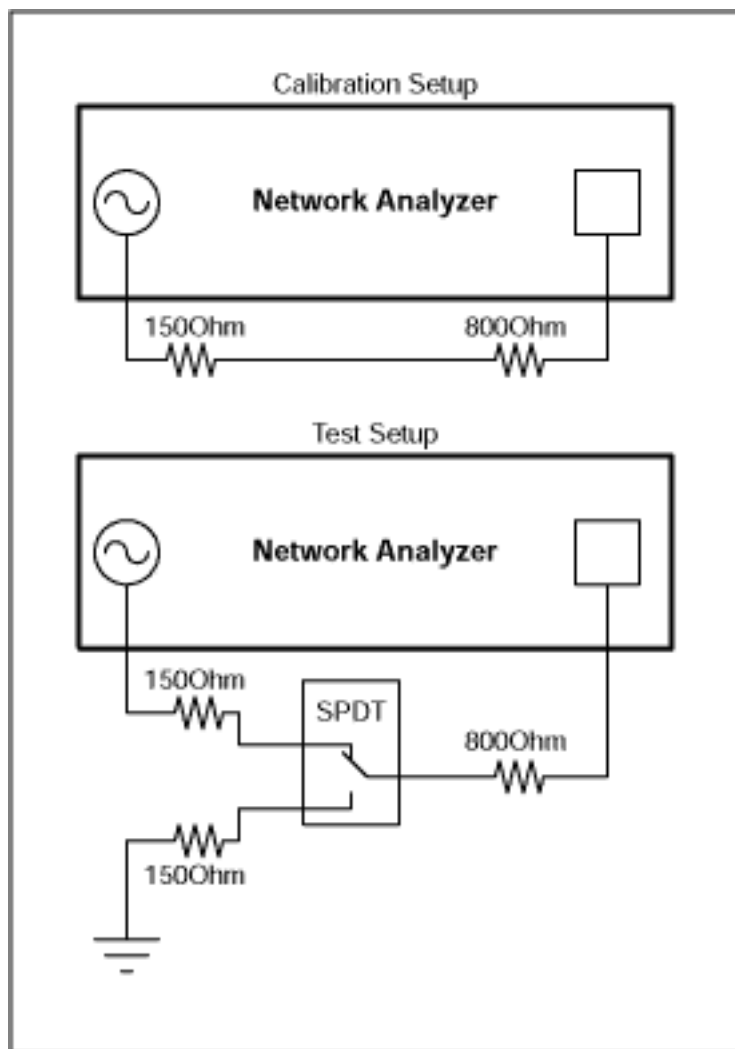

Figure 1.

This situation is improved if the IF SAW filter is matched to a 50Ω switch and then the 50Ω switch is matched to the high impedance IF VGA (see Fig. 2).

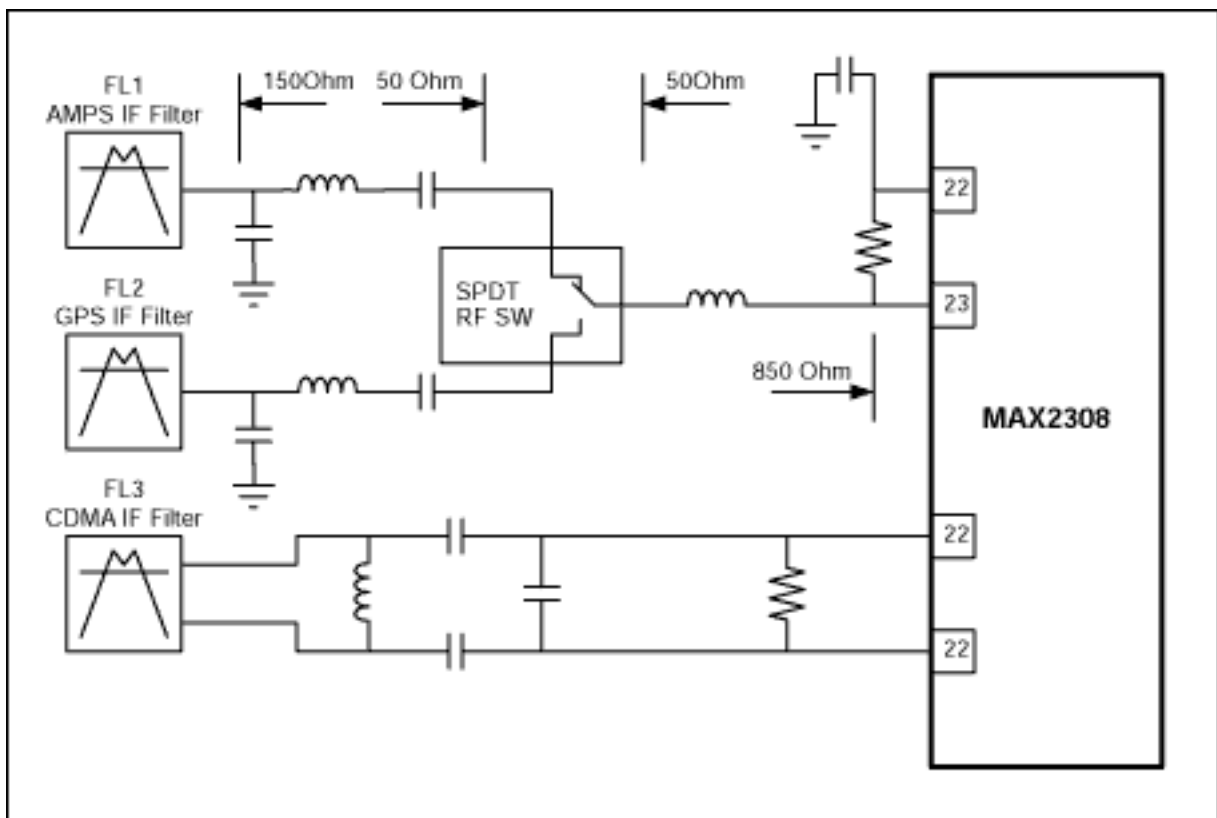

Figure 2.

This solution has some benefits and well as some disadvantages.

The benefits include:

1. The insertion loss of the RF switch is lowered to about 3 dB or less. {Most GaAs FET rf switches are not optimized for use on frequencies of lower than 500MHz. Above 500 MHz these types of switches achieve insertion loss of better than 1 dB.}
2. The providing of a convenient 50 $\Omega$  reference point for tuning the IF SAW matching network. Though this benefit was not intended, it turns out to be very handy when the system is being initially debugged and optimized.

The disadvantages include:

1. An additional matching network must be designed and placed on the PCB.
2. The required high impedance-transformation ratio places more constraints on the components. High Q and precision components must be used.
3. High value, high Q, tight-tolerance inductors are physically large and often may need special shielding.
4. The extra components, often non-standard value or tolerance, make the BOM unattractive.

## Topology to Support Three IF Filters

The MAX2308 has two differential inputs: one of them is used for the CDMA IF input, and the

other input is used in a single-ended configuration. The single-ended mode wastes  $\frac{1}{2}$  of the differential input by bypassing the input to ground to make it AC grounded. Understandably, this single ended configuration is used because commutating differential matching networks greatly complicates the schematic beyond any reasonable benefit.

Another solution is to connect each IF filter through an appropriate matching network to each side of the differential IF VGA. In parallel, each input of the IF VGA is connected through a "large" capacitor to inputs of a SPDT RF switch. The output of the switch is then AC grounded. In operation the desired IF path is selected by employing the RF switch to AC ground the unused path. Because the VGA inputs and the IF SAW output matching networks are high impedance circuits, the switch impedance provides near-perfect short at the IF frequency. Another benefit of this approach is that the switch introduces little or no loss into the path of the active IF filter. An example of this solution is shown in figure 3.

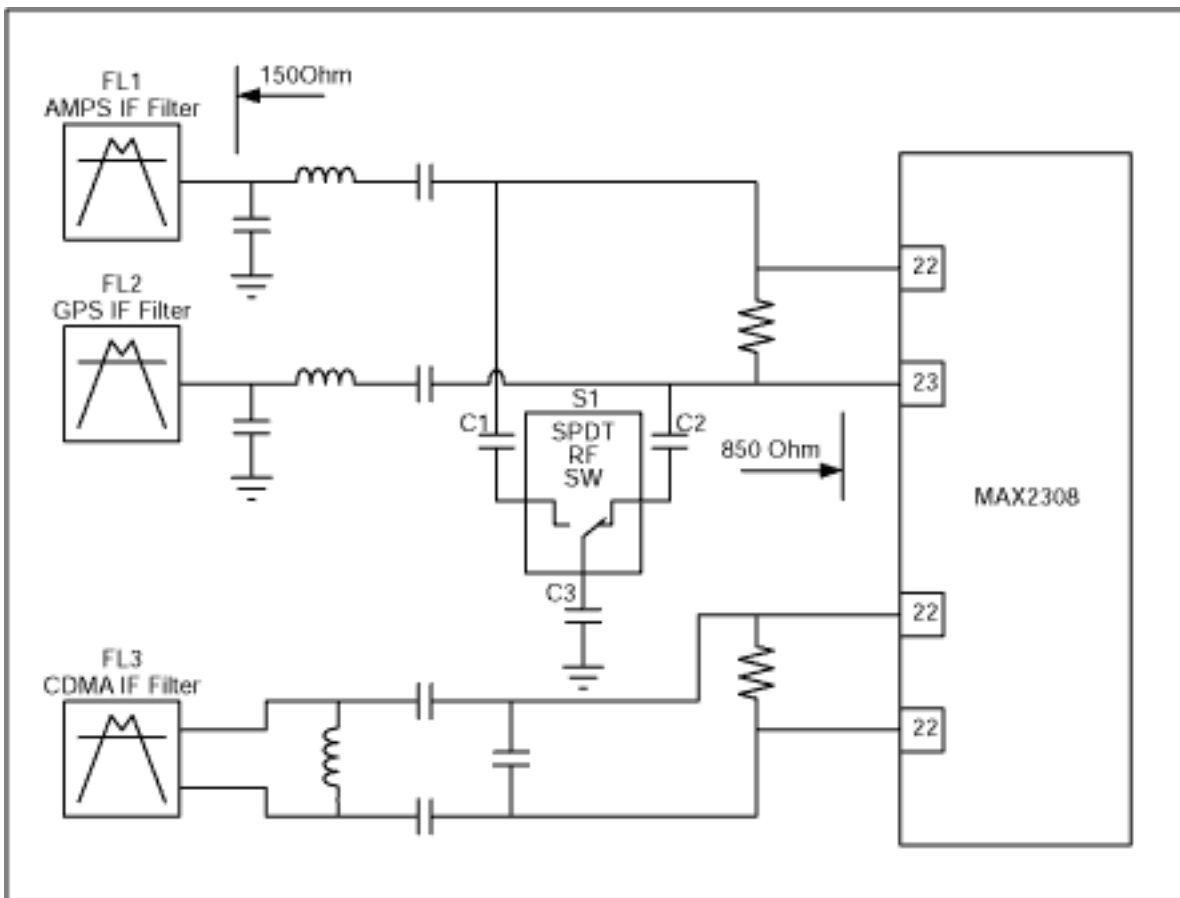

Figure3.

### More Information

MAX2308: [QuickView](#) -- [Full \(PDF\) Data Sheet](#) -- [Free Samples](#)